

# SAC SILK GlowMaster KT88 true balanced Class A Power Amplifier



This amplifier is the second generation of the GlowMaster Series KT-88 push-pull. A new goal was set



to implement the newest true balanced circuit topology from input stage, driving stage and output stage to ensure the absolute purity and authority of signal transmission that is better than any conventional unbalanced amplifier. The true balanced circuit is based on a new balanced amplification principle which is utilized to help cancel harmonic distortion that enables the design to focus on finding the most linear portion of each circuit stage in order to realise the fullest linearity and minimising the use of negative feedback.

The balanced signal transmission principle can be viewed as separate circuits working in parallel that have signal in opposite phase. Thus any noise and distortion that occur will be cancelled out at the output stage. Since the distortion of the balanced circuit is so low, the new GlowMaster requires only a very small amount of negative feedback. The benefits of this are significant in helping to eliminate phasing problems usually associated with high feedback circuits.

That's why the New GlowMaster KT-88 has true wide bandwidth 100KHz, -1.25dB with very low harmonic distortion.

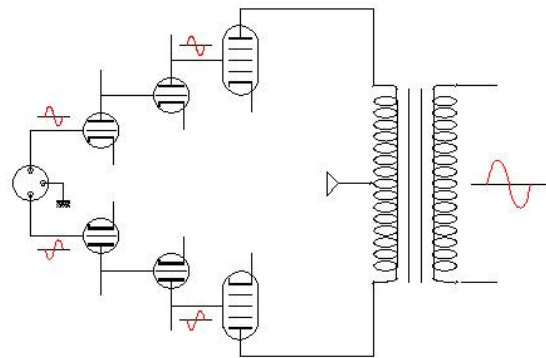

two  
be  
a  
are  
of

Without the new development of SILK P-4200 balanced output transformer, the performance of a true balanced circuit in the New GlowMaster KT-88 cannot be fully realised. Other balanced push-pull amplifiers can produce very distorted waveforms at high frequencies and when driving an unbalanced capacitive load. (Most loudspeakers have a passive crossover network comprised of R/C/L). Even driving a load with a very small capacitive value of a few pico farads, other balanced output transformers from other manufacturers display abnormal behaviour (this happens to be the case when just connecting an oscilloscope which has only 3pF shunt capacitor at input terminal to see the signal trace). SILK P-4200 Balanced output transformer uses our own special balanced winding technique to counter this effect so it can handle unbalanced capacitive load without any problems and extend the quality of balanced circuitry to the limits.

The new class-leading power supply transformer (SILK Special layered wound) with +700VA is the main power source to supply all current needed to drive the GlowMaster KT-88. There is a special electro-static shield built into the main transformer so this amplifier can be used in an environment where high voltage noise would normally cause system instability. Further, the main transformer also features an electro-magnetic shield to suppress any magnetic flux leakage to the sensitive input circuit. The main power supply is separated into high voltage for output tubes and low voltage for input and driver tubes. The high voltage power supply has a large DC choke with



low output impedance to smooth out the supply ripple and provide very stable voltage. Low voltage is a dedicated regulated supply that has more than 105dB of ripple rejection. Bias adjustment voltage is also regulated to maintain the most stable voltage.

The input and driver circuits use 3 x 6N1P double triode per channel.

The 6N1P tube has a gold plated grid and offers the best sounding characteristic of any input tube. These tubes are selected to match with the requirements of the balanced input/driver circuit. The output tubes are hand selected matched quad KT-88.

The new GlowMaster KT-88 has output power of 65 watt RMS per channel, but the true reserve power (peak instantaneous power) of close to 100 watt/Channel. At clipping (soft clipping) GlowMaster develops 80Watt RMS. A high output power is not always a guarantee that the amplifier will have superb driving power. The true specifications that indicate true driving force are output impedance and damping factor. The majority of KT-88 push-pull amplifiers have more than 2 ohm output impedance and a damping factor of less than 5. Even if such an amplifier can produce 150 watt per channel, it will sound flabby and slow when compared with the new Glowmaster KT-88.

With hundreds of hours of fine tuning, the new GlowMaster KT-88 boasts an output impedance of only 0.7 ohm while damping factor is 10.5 or better. This means that new GlowMaster has broken the limitation of regular vacuum tube designs for under 100 watt RMS per channel amplifier. Its low output impedance and high damping factor means that it can fully control any loudspeaker with precise timing and pace even from low listening level to the highest level. Its true wide bandwidth means that it can equally render music signal and capture all harmonic overtone of each instrument without bandwidth limitation. Its ultra low harmonic distortion combine with true wide bandwidth characteristic allow new GlowMaster KT-88 user to hear details and inner details at all listening level.

The new GlowMaster KT-88 performance enters new era of true high definition vacuum tube amplifiers.

Built to withstand the test of time, the massive chassis with beautiful tube cages and gorgeous front acrylic plate offer high class look and aesthetic. Transformers are housed in separate SILK cases to minimize vibration and noise. This also makes future upgrades a very easy task



New GlowMaster KT-88 features high quality parts through out the circuit. Point to point hand wiring is used for all signal path to maximise the signal transmission. SAC uses high quality Amphenol XLR input, Gold plated RCA, Heavy duty gold plated (insulated) binding post, Miyama switch, OFC bus wire, silver solder and best of all, the new SILK P-4200 Balanced output transformer. Power transformer is SILK handwound with special electro-static shield and electro-magnetic shield.

This trace shows the output harmonic spectrum of new GlowMaster KT-88 balanced with 1KHz signal at 1 watt into 8 ohm load. THD is -68dB (0.039%) while this number is one of the best prove number for any tube amp, it is more important that -68dB is almost entirely derived from the second harmonic. Second harmonic is very pleasing to ear at low level; moreover, it is very hard to detect the second harmonic even at high level.

This test shows that in most listening session (where 95% of the music passart is under 1 watt) GlowMaster KT-88 will display the best music integrity while not generating harh sound from high order harmonic distortion.

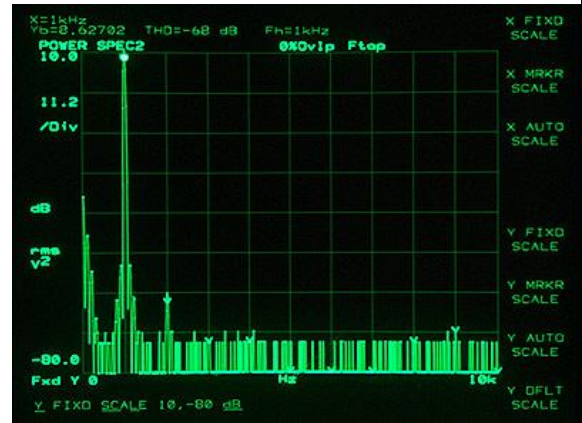

This trace shows the output harmonic spectrum of 10KHz at 1W into 8 ohm load. GlowMaster shows amazing low distortion -68dB (0.039%) same level for 1KHz. This is not easy for other amplifiers to achieve where 1KHz performance may be good, but start to get high distortion at higher frequency.

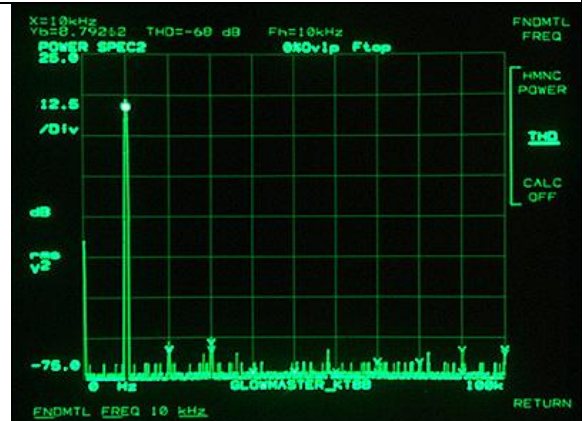

This trace shows harmonic spectrum of a 1KHz signal at 65w into an 8 ohm load. Amazing low distortion of -56dB is obtained

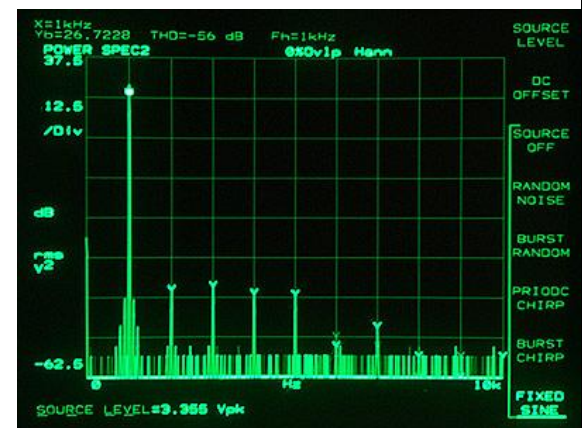

Frequency characteristic of new GlowMaster KT-88 can be seen in this trace. The response can go down to 1Hz up to 100KHz with -1.25dB only. The response can go down to 1Hz up to 100KHz with -1.25dB only

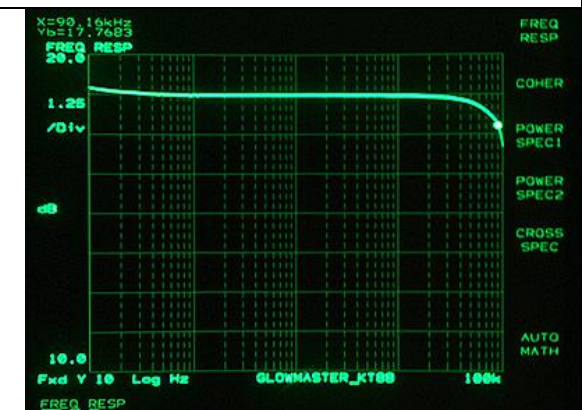

The Frequency response at 65 watt is linear within 0.1dB from 20Hz to 20,000Hz. This is better than most solid state amplifiers (which already use high amounts of negative feedback). The level of accuracy of new GlowMaster KT-88 is only available in reference instruments, which set a new class of its own.

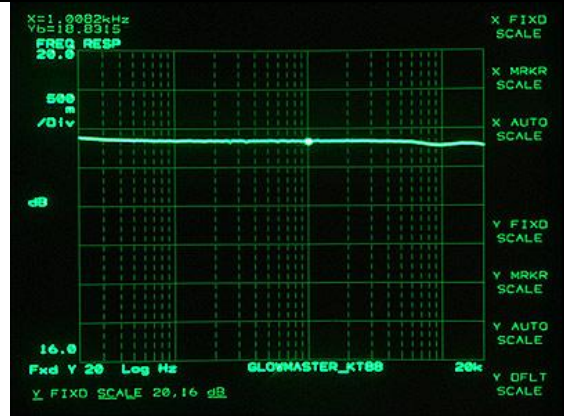

### Specification

Product Type:	Stereo Vacuum Tube Power Amplifier
Feature:	Fully balanced circuit (XLR) from input stage to output Front LCD monitor real time current of each output tube
Input/Driver Tubes:	Matched triple 6N1P
Output Tubes:	Matched quad KT88
Rectifier :	1.5KV/1500mA Hi-speed Damper Diode
Filter Capacitor:	Audiophile Grade Rubycon
Filter Choke:	Low Loss 2H/500mA
Coupling Capacitors:	Solen Fast Capacitor
Signal Resistors:	Precision Metal film
Output Transformer:	SILK P-4200(Balanced) Precision Hand-wound Output Transformer
Output Power:	65 watts RMS/CH (THD less than 0.15%)
(measure with 225V AC line voltage)	80 watt RMS/CH (THD less than 1%)
Frequency Response :	1-100,000Hz (-1.25dB) at 1 watt
Frequency Response :	20-20,000Hz (-0.1dB) at rated power
Input Sensitivity:	1.2V for rated power output
Input Impedance:	200K ohm XLR, 100K ohm RCA
Overall Gain:	26.5dB
Damping Factor:	10.5
Output Impedance:	0.7 ohm
THD at 1 Watt:	0.039% or -68dB
THD at 65Watt	0.15% or -56dB
S/N ratio:	better than - 98dB
Size:	(W) 43 x (D) 37 x (H) 20 cm.
Weight:	28.5 kg. (62.7lbs)
Shipping Weight:	Approx 32 kg.